

Existence of Nash Equilibria on Convex Sets

Jeffrey S. Banks

Division of Humanities and Social Sciences
California Institute of Technology
Pasadena, CA 91125

John Duggan

Department of Political Science
and Department of Economics
University of Rochester
Rochester, NY 14627

April 16, 2001

Abstract

We analyze a non-cooperative game in which the set of feasible strategy profiles is compact and convex but possibly non-rectangular. Thus, a player's feasible strategies may depend on the strategies used by others, as in Debreu's (1952, 1982) generalized games. In contrast to the model of Debreu, we do not require preferences to be defined over infeasible strategy profiles, and we do not require a player's feasible strategy correspondence to have non-empty values. We prove existence of Nash equilibria under a lower hemicontinuity condition, and we give examples of classes of games in which this condition is satisfied.

1 Introduction

In this paper we prove the existence of Nash equilibria in games in which the set of feasible strategy profiles is a compact and convex subset of finite-dimensional Euclidean space. In particular, we allow the set of strategies feasible for one player to depend on the strategies adopted by others. In addition to compactness and convexity, we assume that the payoff functions of the players are continuous and quasi-concave and that each player's feasible strategy correspondence, essentially "slices" from the set of feasible profiles, is lower hemicontinuous. We verify that this condition is satisfied if the set of feasible strategy profiles is strictly convex or is a simplex, as when profiles correspond to allocations of a fixed resource across a finite number of uses.

Our interest in the issue of strategic dependence in games stems from two observations. First, some situations are most parsimoniously modelled in a way that involves such dependence. A group of oil producers, for example, cannot decide independently how much oil to pump from a common well, because the total amount pumped cannot exceed the amount of oil in the ground. In the realm of politics, a committee may be able to influence spending on a particular program but, if the total budget is constrained, not independently of the decisions of other committees. More generally, each committee may be able to influence some dimension of social policy, which is subject to convex fiscal, technological, or legal constraints. Second, models that allow for strategic dependence can be useful as analytic devices, as in the proof of existence of competitive equilibrium (see Arrow and Debreu (1954)) or of an "issue-by-issue median" (see Kramer (1972) and Shepsle (1979)).

Of course, we are not original in taking up the question of existence in this setting. Debreu (1952, 1982) allows for strategic dependence in developing the framework of generalized games. As well, Rosen (1965) permits

dependence in his study of “concave” games. An advantage of our approach is that, unlike Debreu and Rosen, we only need preferences defined on the set of feasible strategy profiles, and not on profiles that could never actually obtain. Unlike Debreu, we take the set of feasible strategy profiles (rather than feasible response correspondences) as primitive. Thus, our conditions for equilibrium existence do not concern a player’s responses to infeasible combinations of strategies. Unlike Rosen, who assumes preferences have concave numerical representations, we use only quasi-concavity.

After introducing our model and establishing conditions for equilibrium existence, we end by relating our result to this earlier work in terms of the assumptions on preferences and strategy sets.

2 The Environment

Let $N = \{1, \dots, n\}$ denote the set of players, with a strategy for player i being represented by an element s^i of \mathfrak{R}^{m^i} , $i = 1, \dots, n$, with $s = (s^1, \dots, s^n) \in \mathfrak{R}^m$ denoting a strategy profile and $m = \sum m^i$. (Throughout the paper, superscripts will index players, and subscripts will index dimensions in \mathfrak{R}^m .) Feasible strategy profiles lie in the set $S \subseteq \mathfrak{R}^m$, where S is assumed to be non-empty, compact, and convex. The set S determines for each $i \in N$ a correspondence $F^i: S \rightarrow S$ identifying the feasible changes in a profile s that player i can induce:

$$F^i(s) = \{t \in S \mid t^{-i} = s^{-i}\},$$

where, for any $s \in S$, $s^{-i} = (s^1, \dots, s^{i-1}, s^{i+1}, \dots, s^n)$. Alternatively, given the Euclidean structure of the strategy spaces, we can write this as

$$F^i(s) = \{t \in S \mid t = s + \sum_{j \in d^i} \lambda_j e_j, \lambda_j \in \mathfrak{R}\},$$

where d^i denotes the “dimensions” of S under i 's control, and, for all $j \in d^i$, e_j is the usual basis vector for the j th dimension.

From the assumptions on S , we know that, for all $i \in N$ and all $s \in S$, the set $F^i(s)$ is non-empty, compact, and convex; furthermore, F^i is an upper hemicontinuous correspondence: for all $s \in S$ and all open $V \subseteq \mathfrak{R}^m$ such that $F^i(s) \subseteq V$, there exists an open $U \subseteq \mathfrak{R}^m$ such that $s \in U$ and $t \in U \cap S$ implies $F^i(t) \subseteq V$. This follows since S is compact and the graph of F^i is evidently closed (see Border (1985), Theorem 11.9). To this we add the assumption that F^i is lower hemicontinuous (LHC): for all $s \in S$ and all open $V \subseteq \mathfrak{R}^m$ such that $F^i(s) \cap V \neq \emptyset$, there exists an open $U \subseteq \mathfrak{R}^m$ such that $s \in U$ and $t \in U \cap S$ implies $F^i(t) \cap V \neq \emptyset$. In Section 4, we show that the latter assumption is non-trivial.

As for preferences, each $i \in N$ has a continuous utility function $u_i: S \rightarrow \mathfrak{R}$ that is quasi-concave on $F^i(s)$ for all $s \in S$.

3 The Existence Result

We extend the definition of Nash equilibrium to our environment in the obvious way.

Definition: A *Nash Equilibrium* is a strategy profile $s^* \in S$ such that, for all $i \in N$ and all $s \in F^i(s^*)$, $u_i(s^*) \geq u_i(s)$.

Theorem: There exists a Nash equilibrium.

Proof: For all $i \in N$, let $b^i(s) = \arg \max_{t \in F^i(s)} u^i(t)$ denote i 's best feasible responses at s . By the Maximum Theorem, the above assumptions on u^i and F^i imply that the correspondence $b^i: S \rightarrow S$ is upper hemicontinuous and non-empty-, compact-, and convex-valued. Following the steps of Kramer (1972) (who showed the existence of a dimension-by-dimension median in a

spatial voting environment), define the correspondence $B: S \rightarrow S$ by

$$\begin{aligned} B(s) &= \frac{1}{n} \sum_{i \in N} b^i(s) \\ &= \left\{ t \in S \mid t = \frac{1}{n} \sum_{i \in N} t^i \text{ and } t^i \in b^i(s) \text{ for all } i \in N \right\}. \end{aligned}$$

Thus, elements of $B(s)$ are (equally-weighted) convex combinations of individual best responses to s . Since each b^i is upper hemicontinuous and non-empty-, compact-, and convex-valued, so is B (see Border (1985), Theorem 11.27). Therefore, Kakutani's Fixed Point Theorem yields the existence of a strategy profile s^* such that $s^* \in B(s^*)$.

To see that s^* constitutes a Nash equilibrium, note that $s^* \in B(s^*)$ implies that s^* can be written

$$\begin{aligned} s^* &= \frac{1}{n} \sum_{i \in N} t^i \\ &= \frac{1}{n} \sum_{i \in N} [s^* + \sum_{j \in d^i} \lambda_j e_j] \end{aligned}$$

for some $\{\lambda_k\}_{k=1}^m$, where $t^i = s^* + \sum_{j \in d^i} \lambda_j e_j \in b^i(s^*)$ for all $i \in N$. Simplifying,

$$\begin{aligned} s^* &= s^* + \frac{1}{n} \sum_{i \in N} \sum_{j \in d^i} \lambda_j e_j \\ &= s^* + \frac{1}{n} \sum_{k=1}^m \lambda_k e_k, \end{aligned}$$

which implies $\sum_{k=1}^m \lambda_k e_k = 0$. Since the basis vectors are linearly independent, $\lambda_k = 0$ for all $k = 1, \dots, m$. Thus, $s^* \in b^i(s^*)$ for all $i \in N$, and s^* is a Nash equilibrium.

4 Lower Hemicontinuity

One of the advantages of the above formulation is that we can inspect S directly to verify whether LHC holds, without reference to a player's feasible

responses to infeasible combinations of strategies. If S is “rectangular,” i.e., $S = S_1 \times \cdots \times S_m$, then F^i is a constant correspondence and so satisfies LHC (giving the usual Nash existence result).

Next, we give two conditions on S sufficient for LHC, both of which are independent of how the dimensions of S are assigned to the players. Thus, in the remainder of this section, let i and d^i be an arbitrary player and subset of $\{1, \dots, m\}$, respectively. Let $N(s, \epsilon)$ denote the open ball of radius ϵ centered at s , and let $\text{ri}S$ denote the relative interior of S (the interior of S when considered as a subset of $\text{aff}S$, the affine hull of S).

Claim 1: Let S be strictly convex: $s, t \in S$, $s \neq t$, and $\alpha \in (0, 1)$ imply $\alpha s + (1 - \alpha)t \in \text{ri}S$; then F^i is lower hemicontinuous.

Proof: Let $t \in F^i(s) \cap V$, with V open.

(1) $t = s$. Let $U = V$. For all $s' \in U \cap S$, $s' \in F^i(s')$, so $s' \in F^i(s') \cap V$.

(2) $t \neq s$. Let $z(\alpha) = \alpha s + (1 - \alpha)t$, $\alpha \in (0, 1)$; then $z(\alpha) \in F^i(s)$ (since $s, t \in F^i(s)$ and $F^i(s)$ is convex); $z(\alpha) \in \text{ri}S$ (by strict convexity); and, for α close to zero, $z(\alpha) \in V$ (since V is open). Choose one such α , and set $z = z(\alpha)$. Take $\epsilon > 0$ such that $N(z, \epsilon) \subseteq V$ and $N(z, \epsilon) \cap \text{aff}S \subseteq \text{ri}S$. Let $U = N(z, \epsilon)$. For $s' \in U \cap S$, $z + s' - s \in N(z, \epsilon) \subseteq V$. Also, $z + s' - s \in \text{aff}S$, and so $z + s' - s \in \text{ri}S$; in particular, $z + s' - s \in S$. Since $z^{-i} = s^{-i}$ (which is implied by $z \in F^i(s)$), it follows that $(z - s)^{-i} = 0$, i.e., $z + s' - s \in F^i(s')$. Thus, $F^i(s') \cap V \neq \emptyset$.

Hence, any strictly convex set of feasible strategy profiles will possess a Nash equilibrium.

Claim 2: Let S be a polytope, the convex hull of a finite set of vectors; then F^i is lower hemicontinuous.

Proof: We can write S as the (bounded) polyhedron

$$S = \{x \in \mathbb{R}^m \mid p^j \cdot x \geq c^j, j = 1, \dots, l\},$$

where the l vectors $p^j \in \mathbb{R}^m$ and scalars c^j are fixed. Let $t \in F^i(s) \cap V$, with V open. Partition $\{1, 2, \dots, l\}$ into two sets, J_1 and J_2 , as follows:

$$\begin{aligned} J_1 &= \{j \mid p^j \cdot (s - t) \neq 0\} \\ J_2 &= \{j \mid p^j \cdot (s - t) = 0\}. \end{aligned}$$

Take any $j \in J_1$ (since S is bounded, this set is non-empty), so that $p^j \cdot s \geq c^j$ and $p^j \cdot t \geq c^j$, at least one inequality strict. Then, for all $\alpha \in (0, 1)$, $p^j \cdot (\alpha s + (1 - \alpha)t) > c^j$. Since V is open, there exists $\alpha^j \in (0, 1)$ close enough to zero so that $\alpha^j s + (1 - \alpha^j)t \in V$. Let $\alpha^* = \min_{j \in J_1} \alpha^j$, and define $r^* = \alpha^* s + (1 - \alpha^*)t$. Thus, $r^* \in V$ and, for all $j \in J_1$, $p^j \cdot r^* > c^j$. Let V^* be an open subset of V containing r^* such that, for all $s' \in V^*$ and all $j \in J_1$, $p^j \cdot s' > c^j$. Define $U = V^* + (s - r^*)$, an open set containing s .

We claim that $s' \in S \cap U$ implies $F^i(s') \cap V \neq \emptyset$. Specifically, we claim that $s' + (r^* - s) \in S \cap V$. (It follows that $s' + (r^* - s) \in F^i(s')$.) To show $s' + (r^* - s) \in S$, take any j . If $j \in J_1$ then $s' \in U$ implies $s' + r^* - s \in V^*$ and, by construction, $p^j \cdot (s' + r^* - s) > c^j$. If $j \in J_2$ then

$$\begin{aligned} p^j \cdot (s' + r^* - s) &= p^j \cdot s' + (1 - \alpha^*)p^j \cdot (t - s) \\ &= p^j \cdot s' \\ &\geq c^j. \end{aligned}$$

Thus, $s' + (r^* - s) \in S$. Finally, $s' + (r^* - s) \in V$ follows from $s' \in U = V^* + (s - r^*)$ and $V^* \subseteq V$.

If S is a simplex, therefore, as when the issue at hand is the allocation of a limited resource across a finite number of uses, a Nash equilibrium exists.

On the other hand, it is not the case that all compact and convex S give rise to lower hemicontinuous F^i correspondences. The following example demonstrates that Claims 1 and 2 cannot be generalized to allow for curves and flat spots simultaneously.

Example 1: Let $n = 2$, $m^1 = 2$, and $m^2 = 1$. We let player 1 control the first two dimensions and player 2 the third dimension of \mathfrak{R}^3 . The set S , depicted below, is the convex hull of a half-circle in the $s_3 = 0$ plane, with highest point $(0, 1, 0)$, and the point $(0, 1, 1)$.

[Figure 1 here.]

Let $s = (0, 1, 0)$, so $(0, 1, 1) \in F^2(s)$. Taking an open ball of radius $1/2$ around $(0, 1, 1)$, we claim that there is no open set U around s satisfying $F^2(s') \cap N(s, 1/2) \neq \emptyset$ for all $s' \in U \cap S$. To see this, consider the sequence $\{s^k\}$ converging to s along the edge of the half-circle. For each k , $F^2(s^k) = \{s^k\}$, and therefore $F^2(s^k) \cap N(s, 1/2) = \emptyset$.

5 Related Literature

As mentioned in the Introduction, Debreu (1952, 1982) and Rosen (1965) obtain Nash equilibrium existence results under assumptions different than ours. As here, Rosen starts with a compact and convex set S of feasible strategy profiles, where now P^i denotes the projection of S onto the dimensions in \mathfrak{R}^m associated with player i , and $P = P^1 \times \dots \times P^n$. Rather than assuming lower hemicontinuity of the individual feasibility correspondences, Rosen assumes preferences are defined over all of P , a superset of S , and are represented by a continuous and *concave* utility function. This strengthening of quasi-concavity to concavity is important in the proof, for there the fact that the sum of concave functions is concave is used (whereas the sum

of quasi-concave functions is not necessarily quasi-concave). Furthermore, there exist quasi-concave functions without concave representations (see Arrow and Endoven (1961), Kannai (1977), or Sundaram (1996)). Finally, even the quasi-concave extension of preferences from S to P is not without loss of generality, as the following example shows.

Example 2: As a first step, suppose $n = 2$, $m^1 = 1$, $m^2 = 1$, and S is the unit square in \mathfrak{R}^2 . Give player 1 the utility function $u_1(s_1, s_2) \equiv \sqrt{s_1} + s_2$. Thus, 1's indifference curves are quasi-linear with infinite slope along the vertical axis (when $s_1 = 0$). Now redefine S and u_1 by rotating the above set (with indifference curves) by 45 degrees, as illustrated in Figure 2.

[Figure 2 here.]

We claim that, for this newly defined environment, player 1's preferences cannot be extended to a convex weak order on P . To see this, suppose otherwise and consider strategies s , s' , and t in Figure 2. By construction, s is preferred to s' , and, by convexity, s is preferred to t . Then, by continuity, there exists a strategy t' between t and s close enough to t so that t' is preferred to s' . But this violates convexity.

Debreu (1982) maintains the assumption that quasi-concave utility functions are defined on P and takes feasible strategy correspondences defined on P as primitives for all players.¹ While he allows the set of feasible strategy profiles to be non-convex, he assumes these correspondences are lower hemicontinuous with non-empty values. Formally, Debreu begins with non-empty, compact, and convex sets, $A^i \subseteq \mathfrak{R}^{m^i}$, of "conceivable" strategies for each $i \in N$, and he posits feasibility correspondences, $\hat{F}^i: \prod_{h \in N} A^h \rightarrow A^i$, assumed to be non-empty-, compact-, and convex-valued and continuous.

¹Our result is compared more easily to Debreu's (1982) simplified version of his earlier existence result.

The set S of jointly feasible strategy profiles are then given by the fixed points of the product correspondence $\hat{F} = \hat{F}^1 \times \dots \times \hat{F}^n$, or

$$S = \{s \in \prod_{h \in N} A^h \mid s^i \in \hat{F}^i(s) \text{ for all } i \in N\}.$$

While S need not be convex, preferences need to be defined on all of $\prod_{h \in N} A^h$, and hence on infeasible strategy profiles. Furthermore, because \hat{F}^i has non-empty values, feasible responses to infeasible combinations of others' strategies must be specified. Suppose, for example, that $n = 3$, that $m^1 = m^2 = m^3 = 1$, and that $S = \{x \in \mathfrak{R}_+^3 \mid \sum x_j = 1\}$, where each player i makes a demand s^i ; then \hat{F}_1 must specify at least one feasible strategy for player 1 when faced with the incompatible demands $s^2 = s^3 = 1$.

Denote by “q-extension” the requirement that quasi-concave utility functions are defined on P , by “c-extension” the requirement that concave utility functions are defined on P , and by “non-emptiness” the requirement that non-empty-valued feasible strategy correspondences are defined on P . The next table lists the various requirements of Debreu (1982), Rosen (1965), and the current paper.

	Debreu	Rosen	this paper
q-extension	•	•	
non-emptiness	•		
c-extension		•	
LHC	•		•
convex S		•	•

Thus, we add convexity of S in place of Debreu’s q-extension and non-emptiness conditions, and we add lower hemicontinuity in place of Rosen’s

assumptions on utility functions. We have not found an example of equilibrium non-existence when just one of our conditions is deleted. It is evident, however, that the demands on such an example would be exceptional: if convexity of S were satisfied, LHC (by our theorem) and c -extension (by Rosen's) would be violated; if LHC were satisfied, convexity of S (by our theorem) and q -extension (by Debreu's) would be violated.

Finally, Gale and Mas-Colell (1975) and Schafer and Sonnenschein (1975) have extended Debreu's original existence result to environments with non-ordered preferences. In particular, preferences over strategy profiles may be incomplete and, therefore, may have no numerical representation. This generality does not allow q -extension to be dropped completely, however, because preferences over infeasible strategy profiles are still needed in some situations. Because preferences are assumed to have open graph, if one profile s on the boundary of S is strictly preferred to another profile s' on the boundary, some infeasible profiles must be preferred to others.

References

- [1] K. Arrow and G. Debreu (1954) Existence of an equilibrium for a competitive economy, *Econometrica*, 22:265-290.
- [2] K. Arrow and A. Endoven (1961) Quasi-concave programming, *Econometrica*, 29:779-800.
- [3] K. Border (1985) *Fixed Point Theorems*, New York: Cambridge.
- [4] G. Debreu (1952) A social equilibrium existence theorem, *Proceedings of the National Academy of Sciences*, 38:886-893.

- [5] G. Debreu (1982) Existence of competitive equilibrium, *Handbook of Mathematical Economics*, vol. 2, K. Arrow and M. Intrilligator, ed.s, New York: North-Holland.
- [6] D. Gale and A. Mas-Colell (1975) An equilibrium existence theorem for a general model without ordered preferences, *Journal of Mathematical Economics*, 2:9-15.
- [7] Y. Kannai (1977) Concavifiability and constructions of concave utility functions, *Journal of Mathematical Economics*, 4:1-56.
- [8] G. Kramer (1972) Sophisticated voting over multi-dimensional choice spaces, *Journal of Mathematical Sociology*, 2:165-180.
- [9] J. Rosen (1965) Existence and uniqueness of equilibrium points for concave n -person games, *Econometrica*, 33:520-534.
- [10] W. Schafer and H. Sonnenschein (1975) Equilibrium in abstract economies without ordered preferences, *Journal of Mathematical Economics*, 2:345-348.
- [11] K. Shepsle (1979) Institutional arrangements and equilibrium in multidimensional Voting Models, *American Journal of Political Science*, 23:27-59.
- [12] R. Sundaram (1996) *A First Course in Optimization Theory*, New York: Cambridge.

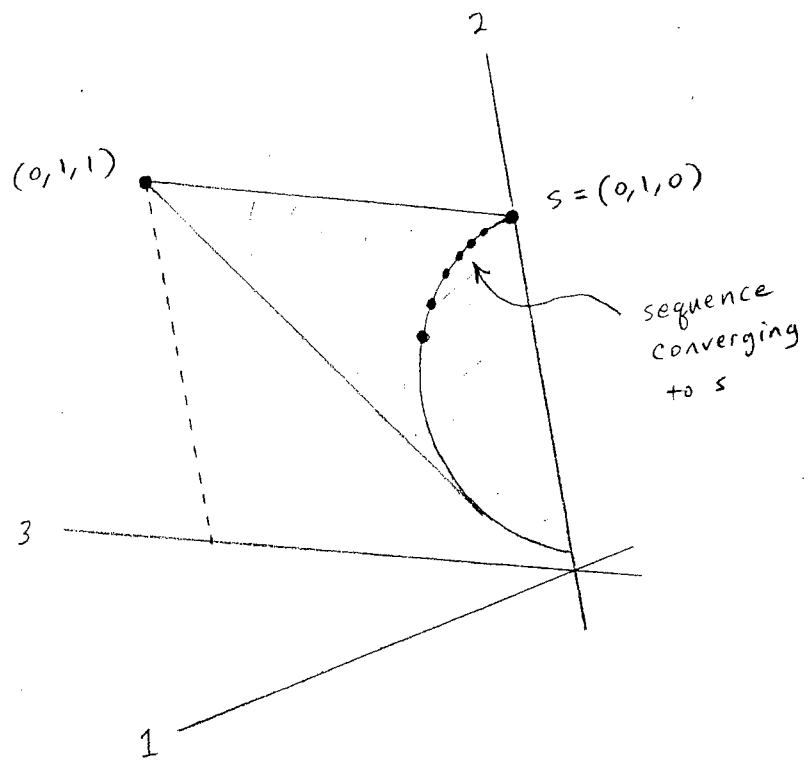

Figure 1

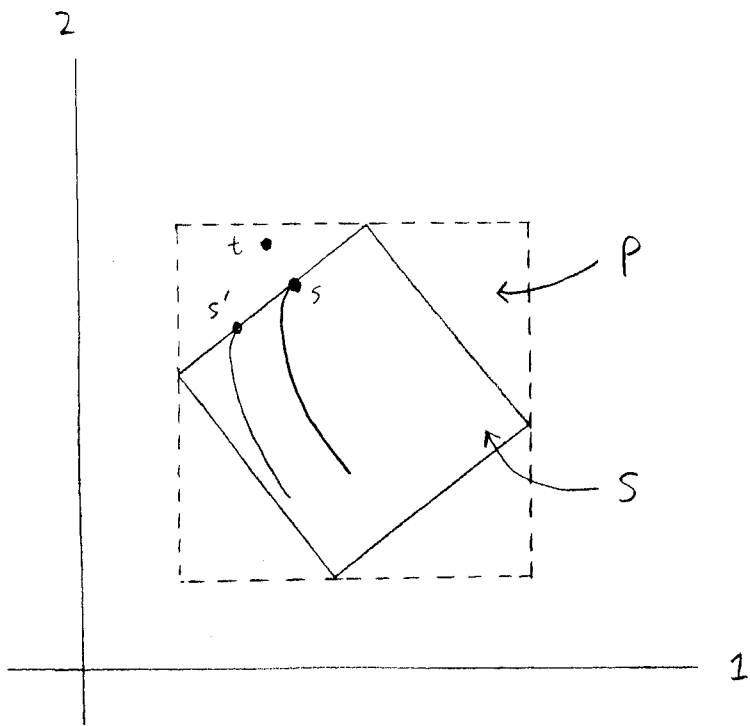

Figure 2

**W. ALLEN WALLIS INSTITUTE OF POLITICAL ECONOMY
1998 - 2001 Working Paper Series**

**University of Rochester
107 Harkness Hall
Rochester, NY 14627**

- WP#11 “Welfare Policy and Endogenous Selective Norms,”
Bird, Edward J., January 1998.
- WP#12 “Does the Welfare State Induce Risk-Taking?,”
Bird, Edward J., February 1998.
- WP#13 “Politics, Altruism, and the Definition of Poverty,”
Bird, Edward J., February 1998.
- WP#14 “Bounds for Mixed Strategy Equilibria and the Spatial Model of Elections,”
Banks, Jeffrey S., John Duggan, and Michel Le Breton, March 1998.
- WP#15 “Interpretation and Coordination in Constitutional Politics”
Randall L. Calvert and James Johnson, July 1998
- WP#16 “Legislative Coalitions in a Bargaining Model with Externalities”
Randall L. Calvert and Nathan Dietz, July 1998
- WP#17 “Establishing Cooperation Without Pre-Play Communication”
Randall L. Calvert. July 1998
- WP#18 “A Bayesian Model of Voting in Juries”
John Duggan and Cesar Martinelli, November 1998
- WP#19 “Electoral Competition with Policy-Motivated Candidates”
John Duggan and Mark Fey, February 2001
- WP#20 “Existence of Nash Equilibria on Convex Sets”
Jeffrey Banks and John Duggan, May 2001
- WP#21 “Non-cooperative Games Among Groups”
John Duggan, May 2001

W. Allen Wallis Institute for Political Economy

Working Paper Series

To order copies of the working papers, complete the attached invoice and return to:

Mrs. Terry Fisher
W. Allen Wallis Institute of Political Economy
107 Harkness Hall
University of Rochester
Rochester, NY 14627.

Three (3) papers per year will be provided free of charge as requested below. Each additional paper will require a \$5.00 service fee which must be enclosed with your order.

An invoice is provided below in order that you may request payment from your institution as necessary. Please make your check payable to the W. Allen Wallis Institute of Political Economy.

OFFICIAL INVOICE

Requestor's Name:

Requestor's Address:

Please send me the following papers free of charge:
(Limit: 3 free per year)

WP# _____ WP# _____ WP# _____

I understand there is a \$5.00 fee for each additional paper.
Enclosed is my check or money order in the amount of \$ _____.
Please send me the following papers.

WP# _____ WP# _____ WP# _____
WP# _____ WP# _____ WP# _____
WP# _____ WP# _____ WP# _____
WP# _____ WP# _____ WP# _____

